

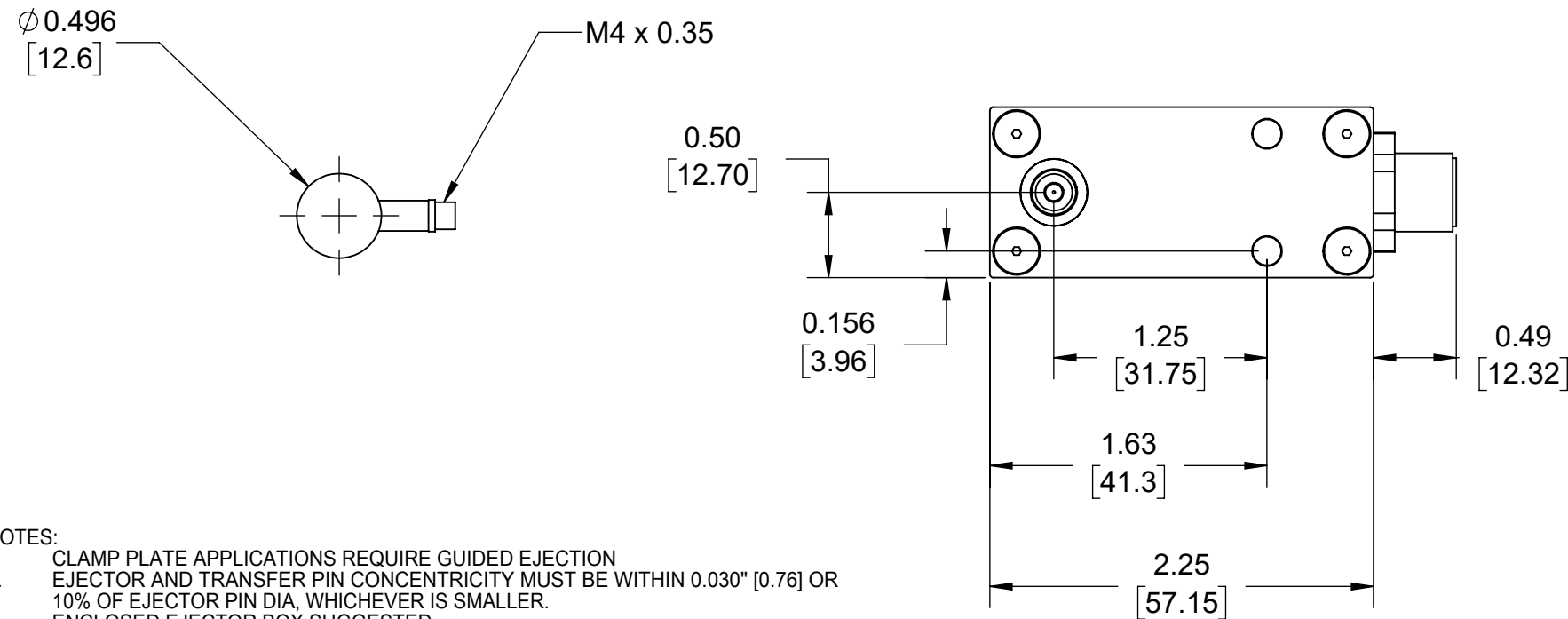

Single-Channel Piezoelectric 12.6 mm Sensor (9204) Installation—Dimensions

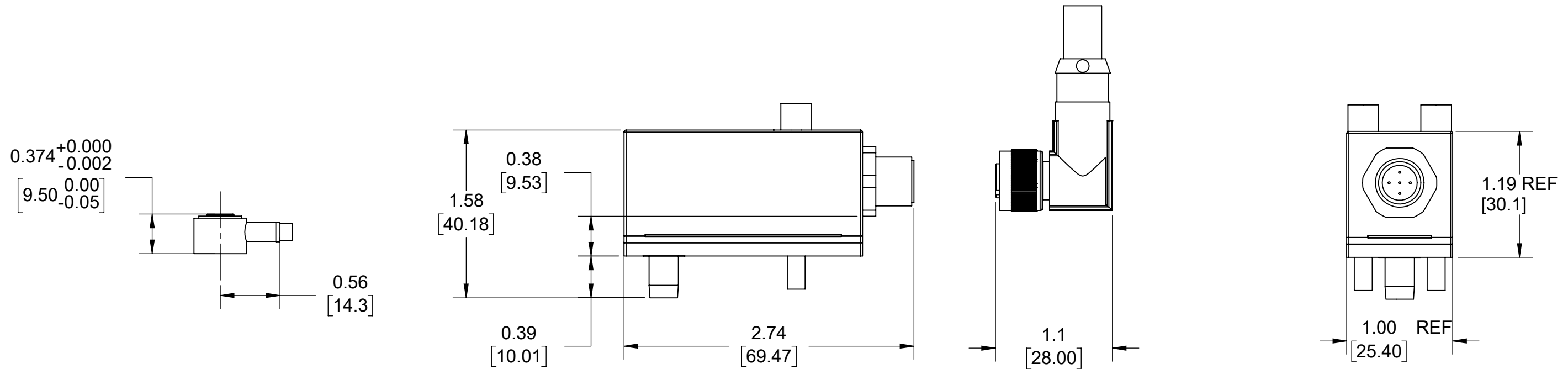

NOTES:

1. CLAMP PLATE APPLICATIONS REQUIRE GUIDED EJECTION
2. EJECTOR AND TRANSFER PIN CONCENTRICITY MUST BE WITHIN 0.030" [0.76] OR 10% OF EJECTOR PIN DIA, WHICHEVER IS SMALLER.
3. ENCLOSED EJECTOR BOX SUGGESTED.
4. DO NOT SCALE PRINT
5. BREAK ALL SHARP EDGES, 0.005 [0.03] R MAX
6. DIMENSIONS IN INCHES [MM], UNLESS NOTED
7. TOLERANCES UNLESS SPECIFIED:
 - XXX = ±0.003 [0.08]
 - XX = +0.01 [0.3]
 - ANGLES = ±3° 30°

 <p>3111 Park Street, Traverse City, MI 49686 231-944-2111 www.rjg.com</p>	Description: 9204 Sensor Installation
	Drawn: K.J.Brettschneider
	Design:
	Check: M.Groleau
Date: 09.24.2021	

Single-Channel 2.6 mm Piezoelectric Sensor (9204) Installation—Clamp Plate Installation

CLAMP PLATE INSTALLATIONS FOR PIN $\leq \varnothing 0.25$ [7.0]; PINS $> \varnothing 0.25$ [7.0] USE HEAD-TO-HEAD INSTALLATION ON SHEET 9204-04 & -05.

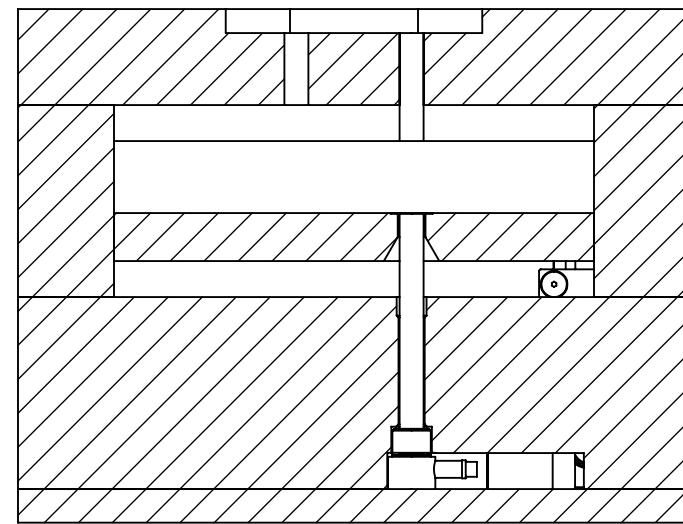
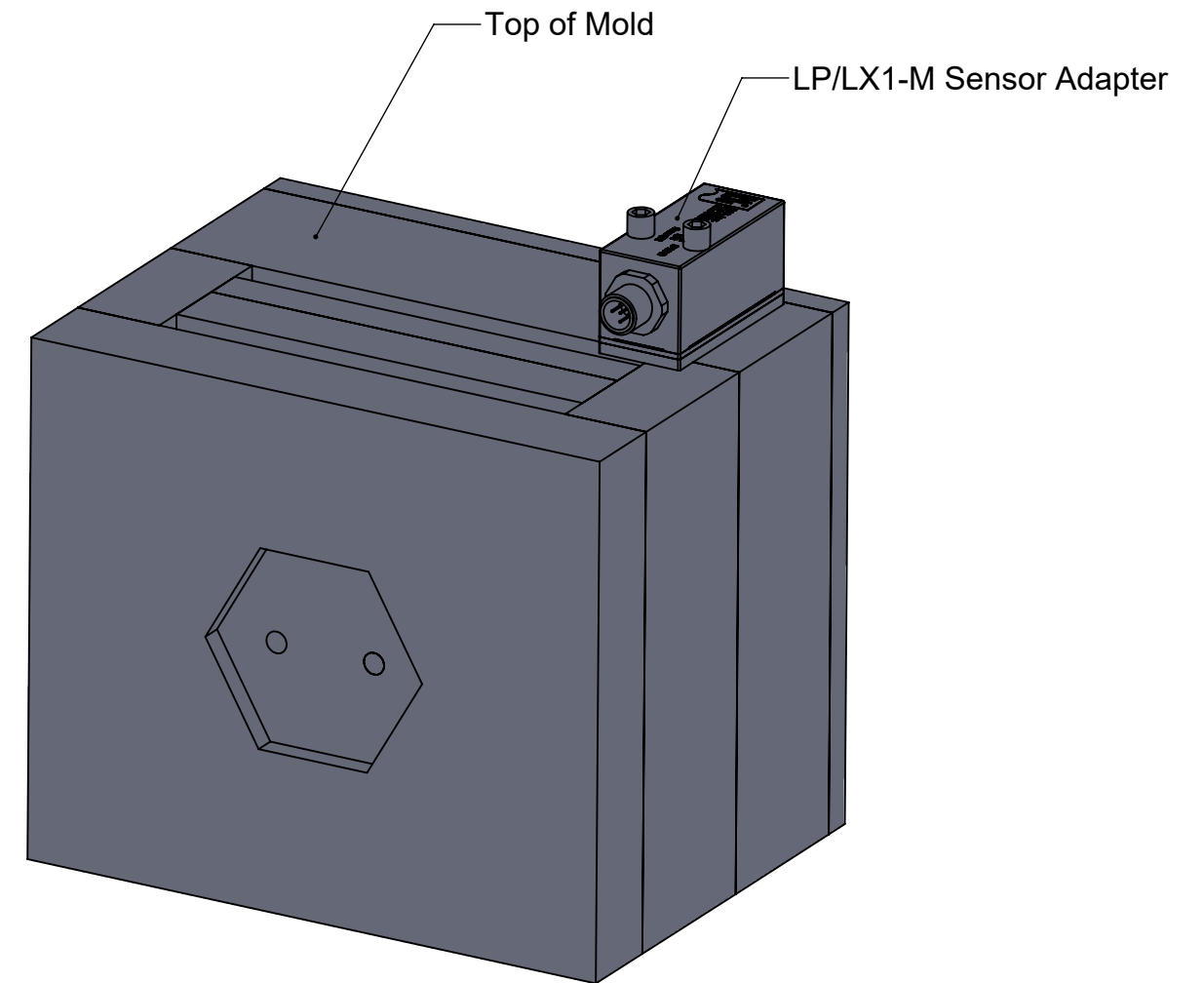
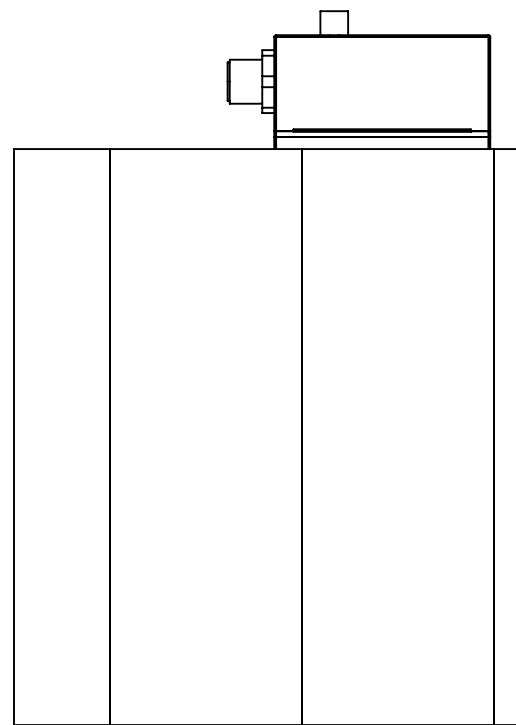
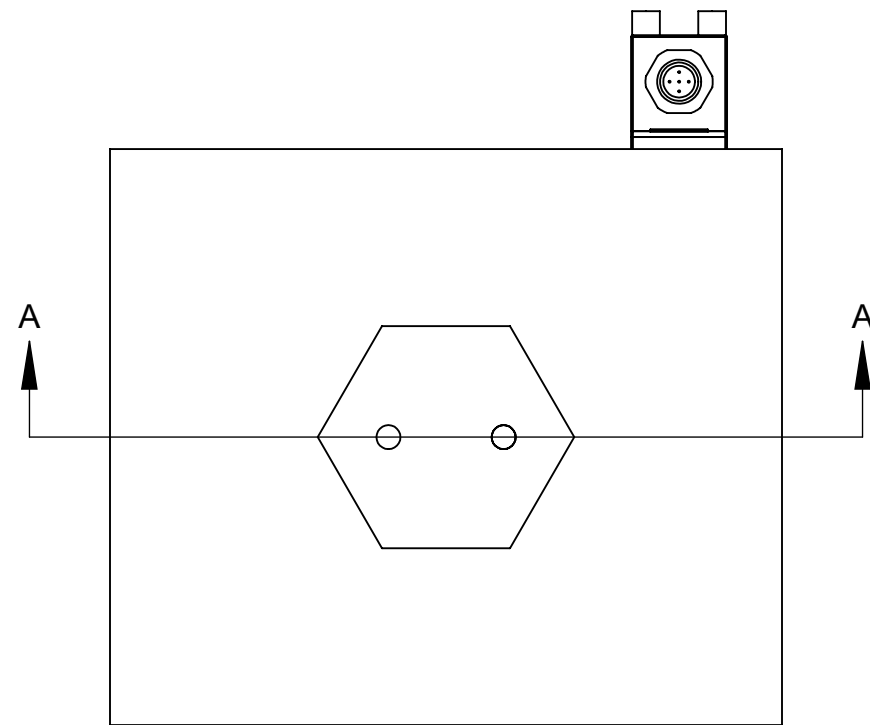

SECTION A-A
SCALE 1 : 2

NOTES:

1. CLAMP PLATE APPLICATIONS REQUIRE GUIDED EJECTION
2. EJECTOR AND TRANSFER PIN CONCENTRICITY MUST BE WITHIN 0.030" [0.76] OR 10% OF EJECTOR PIN DIA, WHICHEVER IS SMALLER.
3. ENCLOSED EJECTOR BOX SUGGESTED.
4. DO NOT SCALE PRINT
5. BREAK ALL SHARP EDGES, 0.005 [0.03] R MAX
6. DIMENSIONS IN INCHES [MM], UNLESS NOTED
7. TOLERANCES UNLESS SPECIFIED:
 XXX = ± 0.003 [0.08]
 XX = ± 0.01 [0.3]
 ANGLES = $\pm 3^\circ 30'$

 <p>3111 Park Street, Traverse City, MI 49686 231-944-2111 www.rjg.com</p>	Description: 9204 Sensor Installation
	Drawn: K.J.Brettschneider
	Design:
	Check: M.Groleau
Date: 09.24.2021	

Drawing Title: 9204-03

Single-Channel Piezoelectric 12.6 mm Sensor (9204) Installation—Clamp Plate Installation

CLAMP PLATE INSTALLATIONS FOR PIN $\leq \varnothing 0.25$ [7.0]; PINS $> \varnothing 0.25$ [7.0] USE HEAD-TO-HEAD INSTALLATION ON SHEET 9204-04 & -05.

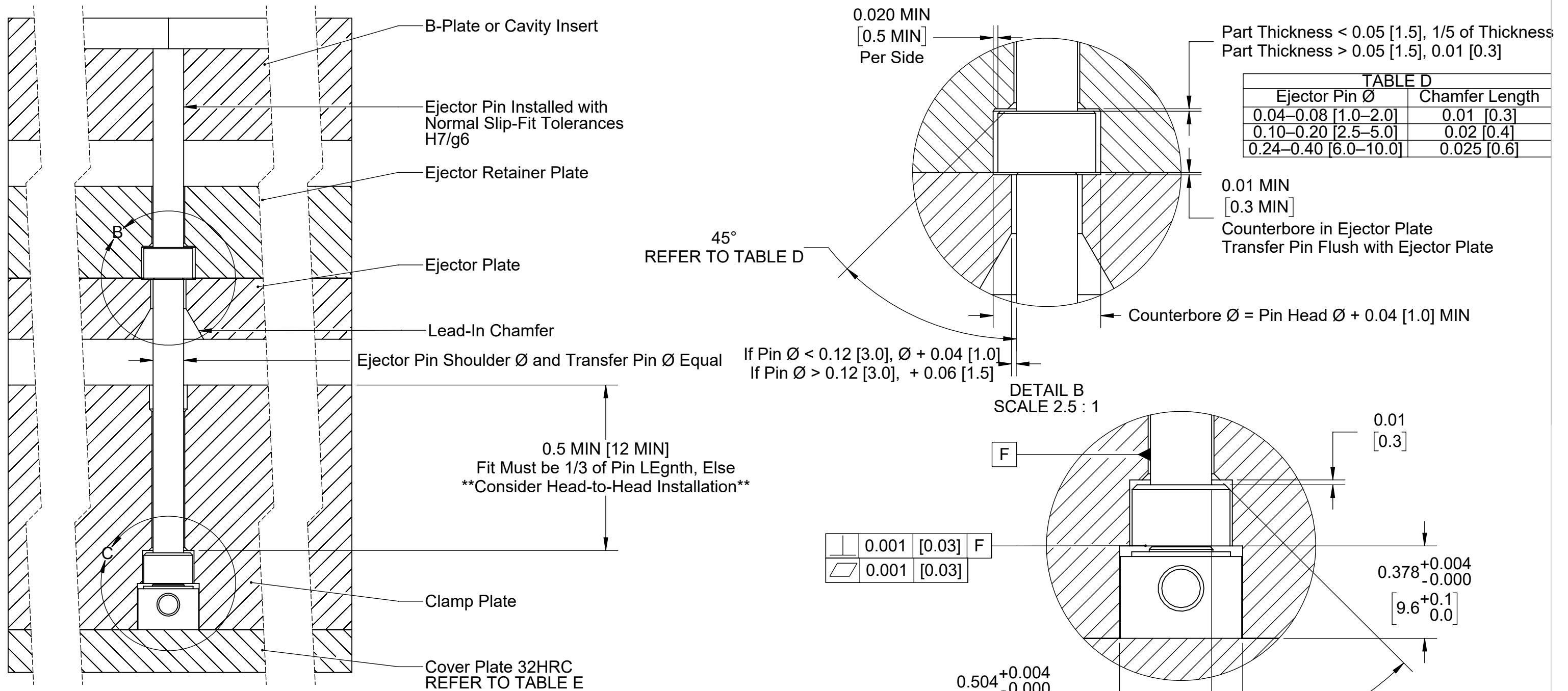

Ejector Pin \varnothing	Chamfer Length
0.04–0.08 [1.0–2.0]	0.01 [0.3]
0.10–0.20 [2.5–5.0]	0.02 [0.4]
0.24–0.40 [6.0–10.0]	0.025 [0.6]

	0.001 [0.03]	F
	0.001 [0.03]	

Pin \varnothing	MIN Plate Thickness
3/32–7/64" [2.5–3.0]	0.2 [5]
9/64"–5/8" [14.0–23.0]	0.25 [6.0]

- NOTES:
1. CLAMP PLATE APPLICATIONS REQUIRE GUIDED EJECTION
 2. EJECTOR AND TRANSFER PIN CONCENTRICITY MUST BE WITHIN 0.030" [0.76] OR 10% OF EJECTOR PIN DIA, WHICHEVER IS SMALLER.
 3. ENCLOSED EJECTOR BOX SUGGESTED.
 4. DO NOT SCALE PRINT
 5. BREAK ALL SHARP EDGES, 0.005 [0.03] R MAX
 6. DIMENSIONS IN INCHES [MM], UNLESS NOTED
 7. TOLERANCES UNLESS SPECIFIED:
 XXX = ± 0.003 [0.08]
 XX = ± 0.01 [0.3]
 ANGLES = $\pm 3^\circ$ 30°

RJG
MOLD SMART

311 Park Street, Traverse City, MI 49606
231-944-2111 | WWW.RJG.COM

Description: 9204 Sensor Installation
 Drawn: K.J.Brettschneider
 Design:
 Check: M.Groleau
 Date: 09.24.2021

Drawing Title: 9204-04

Single-Channel Piezoelectric 12.6 mm Sensor (9204) Installation—Head-to-Head Installation

CLAMP PLATE INSTALLATIONS FOR PIN $\leq \varnothing 0.25$ [7.0]; PINS $> \varnothing 0.25$ [7.0] USE HEAD-TO-HEAD INSTALLATION.

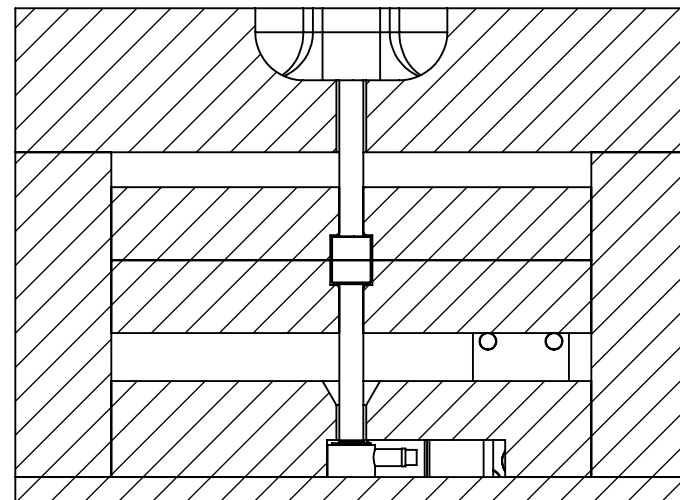
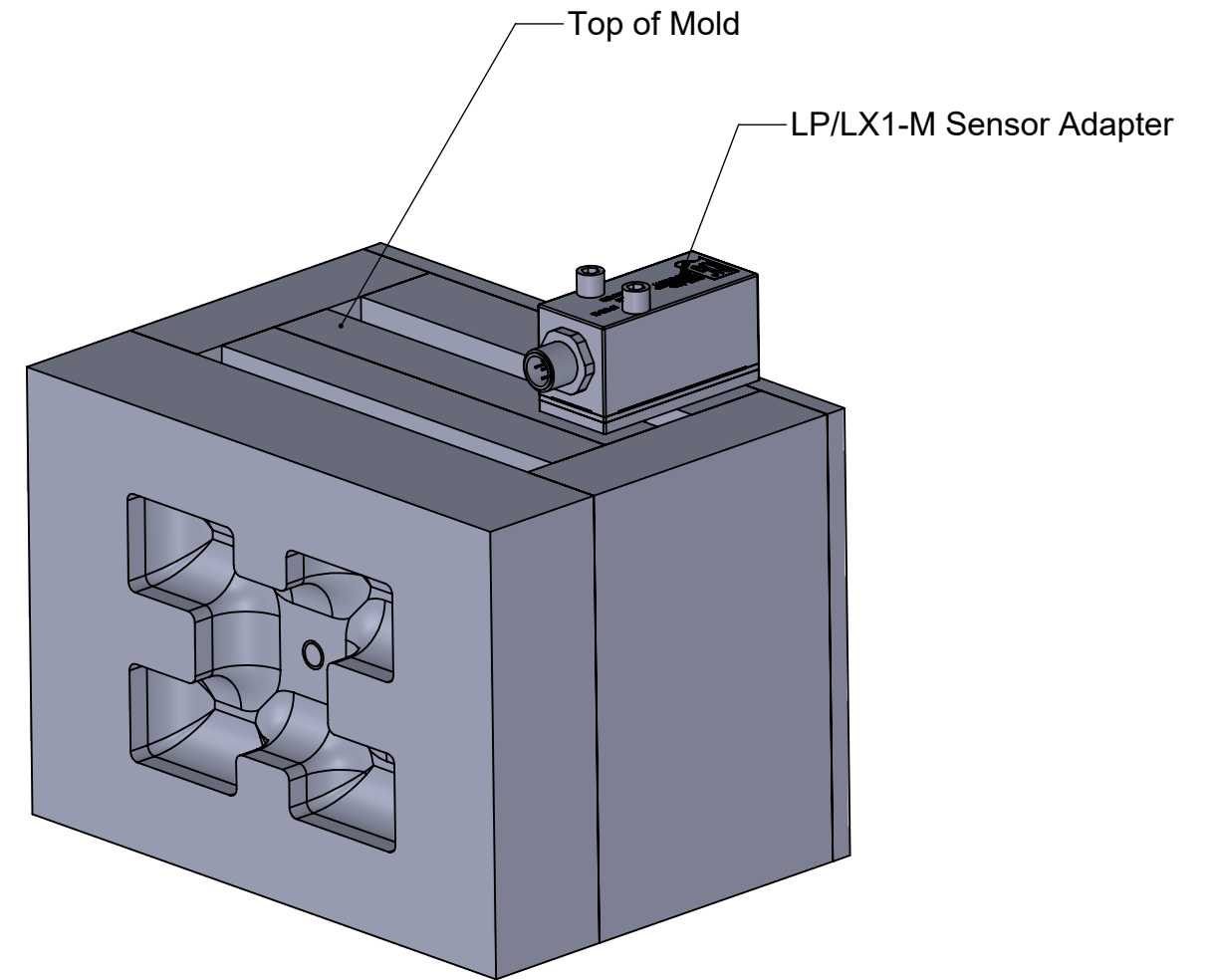
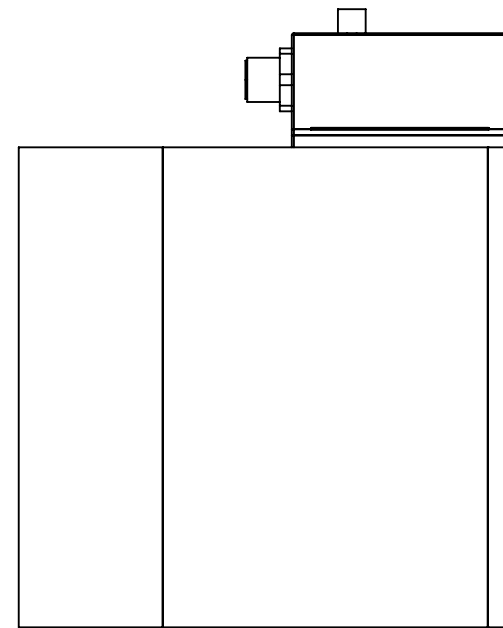
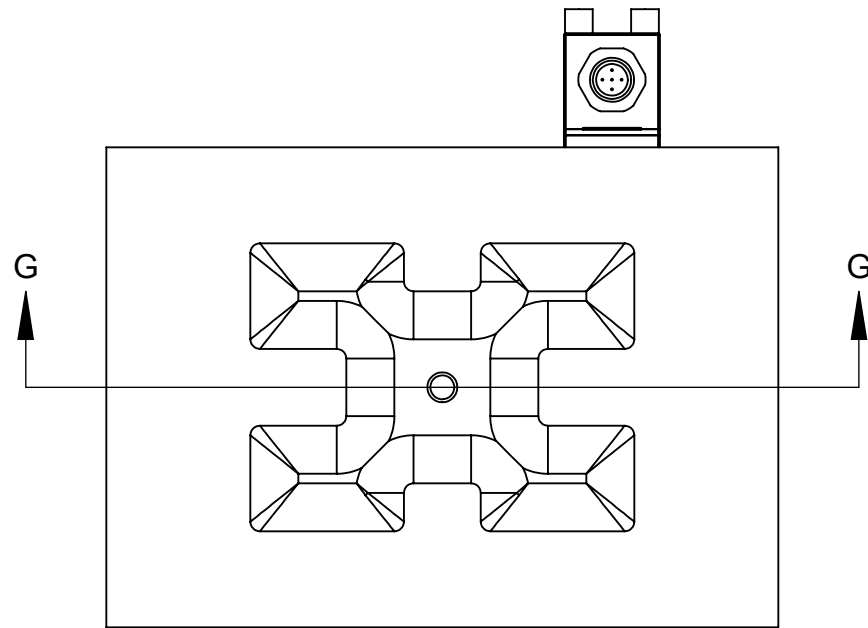

SECTION G-G
SCALE 1 : 2

NOTES:

1. CLAMP PLATE APPLICATIONS REQUIRE GUIDED EJECTION
2. EJECTOR AND TRANSFER PIN CONCENTRICITY MUST BE WITHIN 0.030" [0.76] OR 10% OF EJECTOR PIN DIA, WHICHEVER IS SMALLER.
3. ENCLOSED EJECTOR BOX SUGGESTED.
4. DO NOT SCALE PRINT
5. BREAK ALL SHARP EDGES, 0.005 [0.03] R MAX
6. DIMENSIONS IN INCHES [MM], UNLESS NOTED
7. TOLERANCES UNLESS SPECIFIED:
 XXX = ± 0.003 [0.08]
 XX = $+0.01$ [0.3]
 ANGLES = $\pm 3^\circ 30'$

 <p>3111 Park Street, Traverse City, MI 49686 231-944-2111 www.rjg.com</p>	Description: 9204 Sensor Installation
	Drawn: K.J.Brettschneider
	Design:
	Check: M.Groleau
Date: 09.24.2021	

Drawing Title: 9204-05

Single-Channel Piezoelectric 12.6 mm Sensor (9204) Installation—Head-to-Head Installation

CLAMP PLATE INSTALLATIONS FOR PIN ≤ Ø0.25 [7.0]; PINS > Ø0.25 [7.0] USE HEAD-TO-HEAD INSTALLATION ON SHEET 9204-04 & -05.

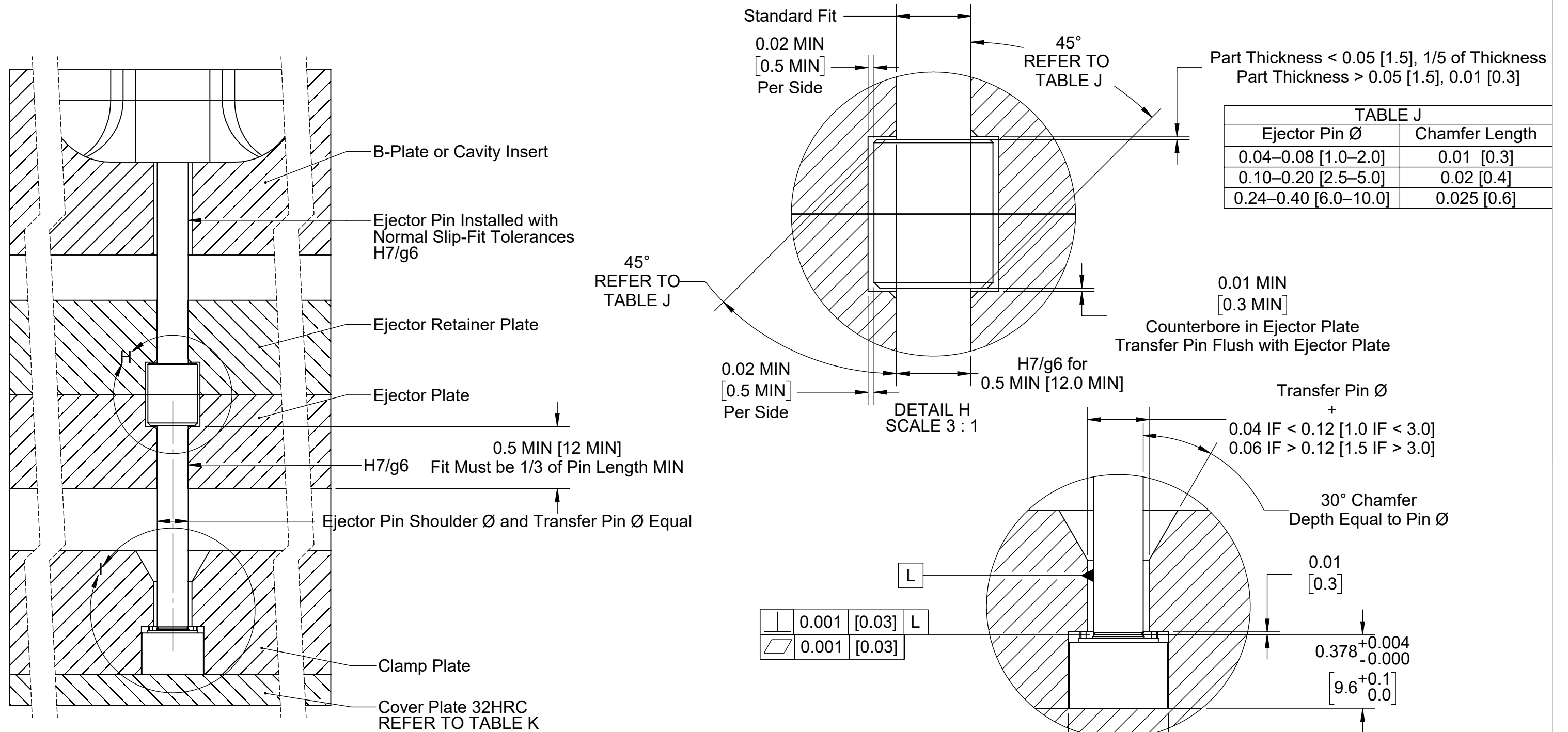

Part Thickness < 0.05 [1.5], 1/5 of Thickness
Part Thickness > 0.05 [1.5], 0.01 [0.3]

TABLE J	
Ejector Pin Ø	Chamfer Length
0.04–0.08 [1.0–2.0]	0.01 [0.3]
0.10–0.20 [2.5–5.0]	0.02 [0.4]
0.24–0.40 [6.0–10.0]	0.025 [0.6]

	0.001	[0.03]	L
	0.001	[0.03]	

TABLE K	
Pin Ø	MIN Plate Thickness
3/32–7/64" [2.5–3.0]	0.2 [5]
9/64"–5/8" [14.0–23.0]	0.25 [6.0]

- NOTES:
- CLAMP PLATE APPLICATIONS REQUIRE GUIDED EJECTION
 - EJECTOR AND TRANSFER PIN CONCENTRICITY MUST BE WITHIN 0.030" [0.76] OR 10% OF EJECTOR PIN DIA, WHICHEVER IS SMALLER.
 - ENCLOSED EJECTOR BOX SUGGESTED.
 - DO NOT SCALE PRINT
 - BREAK ALL SHARP EDGES, 0.005 [0.03] R MAX
 - DIMENSIONS IN INCHES [MM], UNLESS NOTED
 - TOLERANCES UNLESS SPECIFIED:
 XXX = ±0.003 [0.08]
 XX = +0.01 [0.3]
 ANGLES = ±3° 30°

3111 Park Street, Traverse City, MI 49606
231-944-2111 | www.rjgusa.com

Description: 9204 Sensor Installation
Drawn: K.J.Brettschneider
Design:
Check: M.Groleau
Date: 09.24.2021

Drawing Title: 9204-06

Single-Channel Piezoelectric 12.6 mm Sensor (9204) Installation—Clamp Plate/Head-to-Head Installation

NOTE: Lynx sensor electronics case mounted in the orientation as shown to allow access to the Lynx cable connection.
Refer to Product Manual for alternate electronics case mounting options.

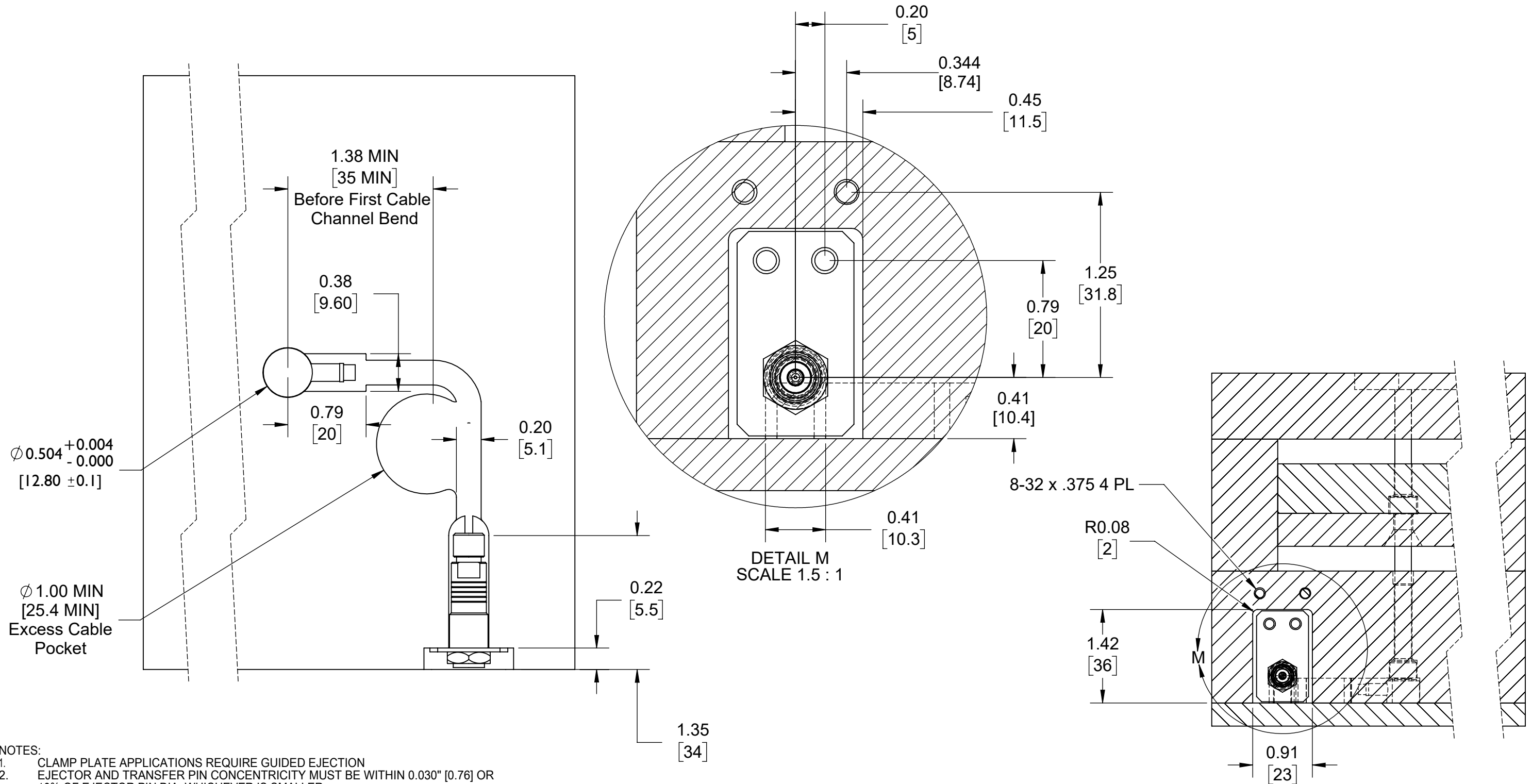

- NOTES:
1. CLAMP PLATE APPLICATIONS REQUIRE GUIDED EJECTION
 2. EJECTOR AND TRANSFER PIN CONCENTRICITY MUST BE WITHIN 0.030" [0.76] OR 10% OF EJECTOR PIN DIA, WHICHEVER IS SMALLER.
 3. ENCLOSED EJECTOR BOX SUGGESTED.
 4. DO NOT SCALE PRINT
 5. BREAK ALL SHARP EDGES, 0.005 [0.03] R MAX
 6. DIMENSIONS IN INCHES [MM], UNLESS NOTED
 7. TOLERANCES UNLESS SPECIFIED:
 XXX = ±0.003 [0.08]
 XX = +0.01 [0.3]
 ANGLES = ±3° 30°

	Description: 9204 Sensor Installation
	Drawn: K.J.Brettschneider
	Design:
	Check: M.Groleau
Date: 09.24.2021	

3111 Park Street, Traverso City, NJ 08086
201-244-2111 | WWW.RJG.MI

Drawing Title: 9204-07

Single-Channel Piezoelectric 12.6 mm Sensor (9204) Installation—Ejector Plate Installation

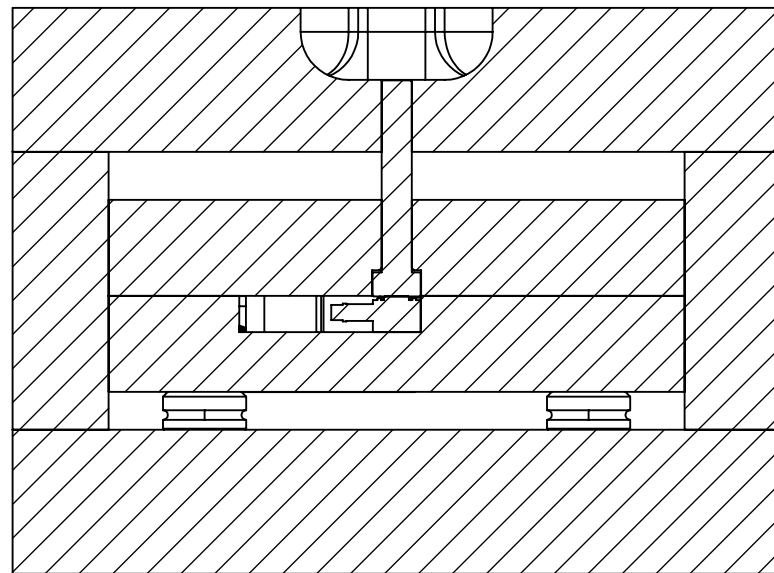
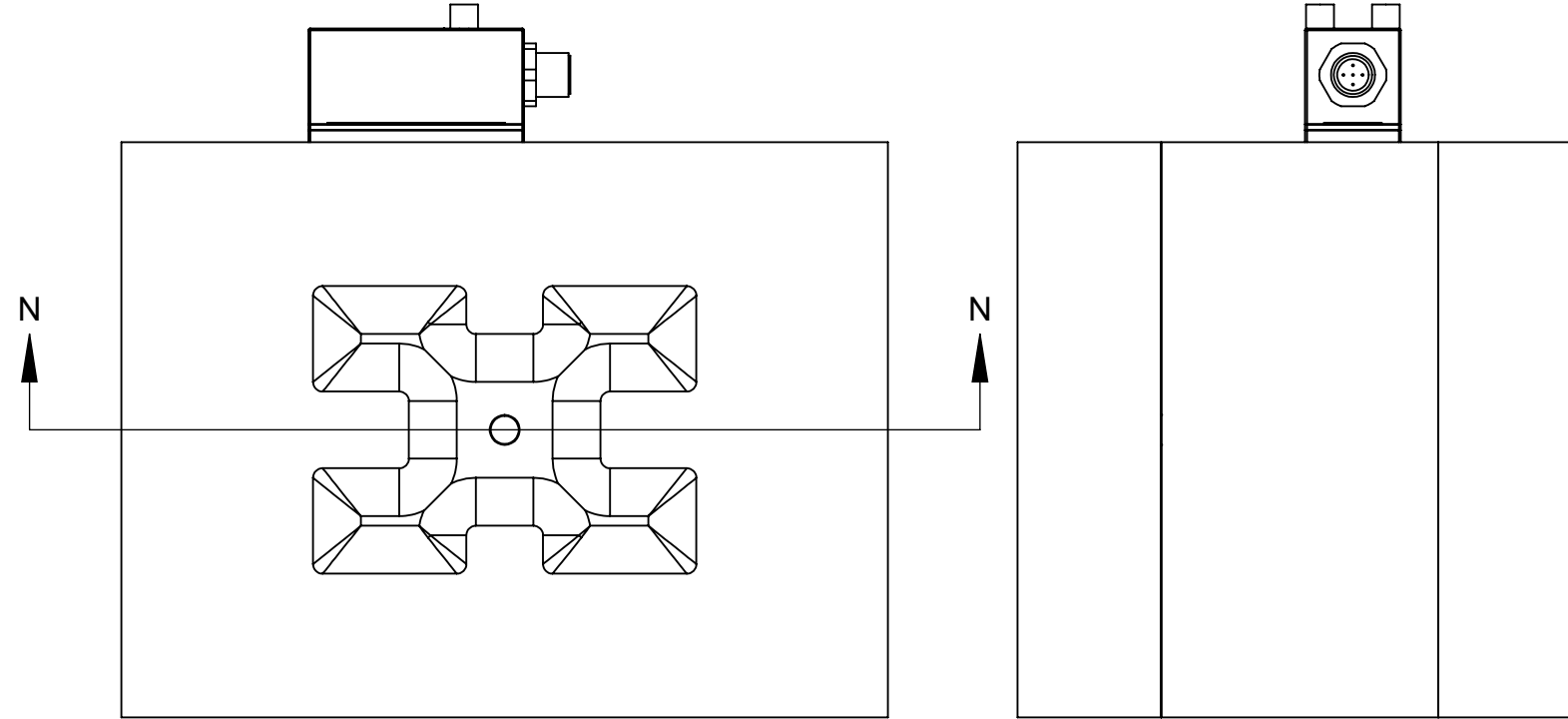

SECTION N-N
SCALE 1 : 2

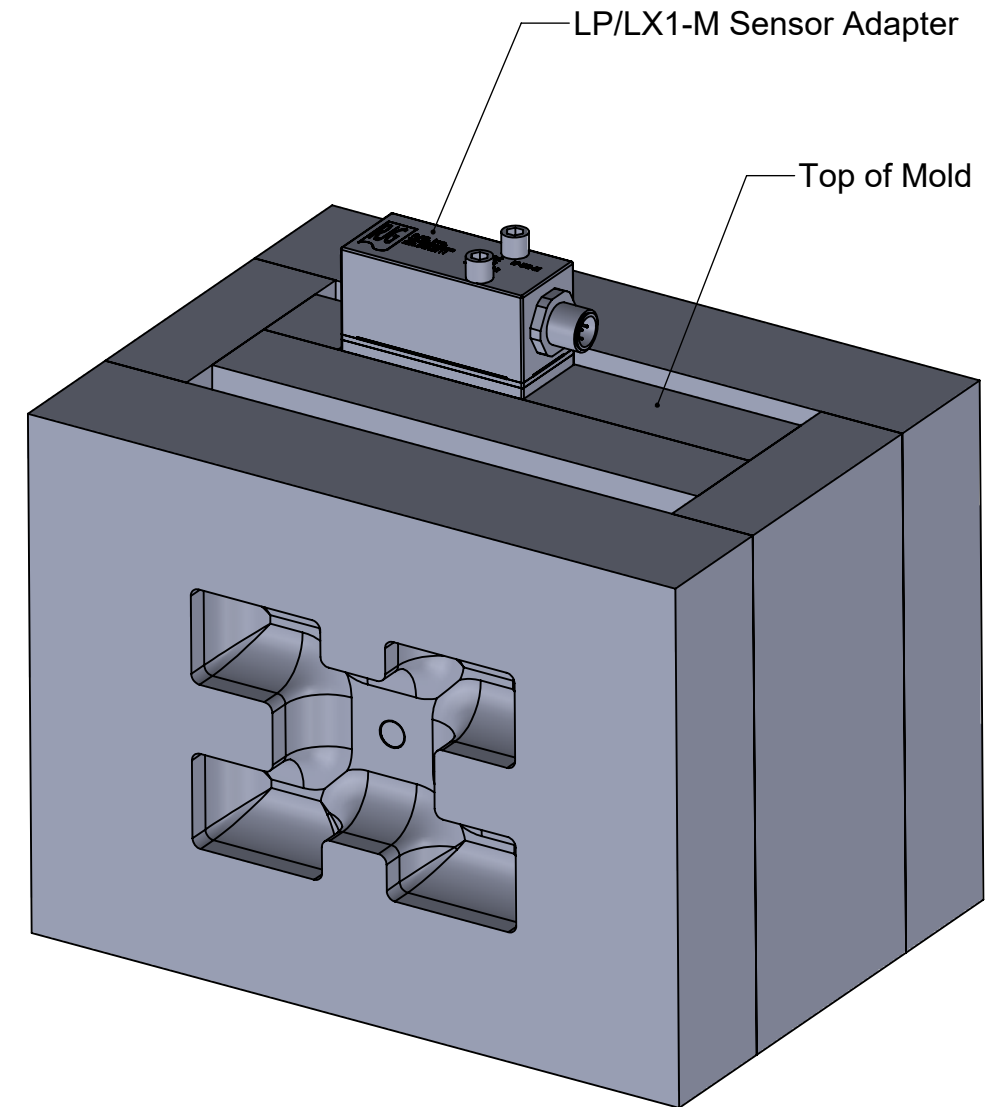

NOTES:

1. CLAMP PLATE APPLICATIONS REQUIRE GUIDED EJECTION
2. EJECTOR AND TRANSFER PIN CONCENTRICITY MUST BE WITHIN 0.030" [0.76] OR 10% OF EJECTOR PIN DIA, WHICHEVER IS SMALLER.
3. ENCLOSED EJECTOR BOX SUGGESTED.
4. DO NOT SCALE PRINT
5. BREAK ALL SHARP EDGES, 0.005 [0.03] R MAX
6. DIMENSIONS IN INCHES [MM], UNLESS NOTED
7. TOLERANCES UNLESS SPECIFIED:
 XXX = ± 0.003 [0.08]
 XX = $+0.01$ [0.3]
 ANGLES = $\pm 3^\circ 30'$



Description: 9204 Sensor Installation
 Drawn: K.J.Brettschneider
 Design:
 Check: M.Groleau
 Date: 09.24.2021

Single-Channel Piezoelectric 12.6 mm Sensor (9204) Installation—Ejector Plate Installation

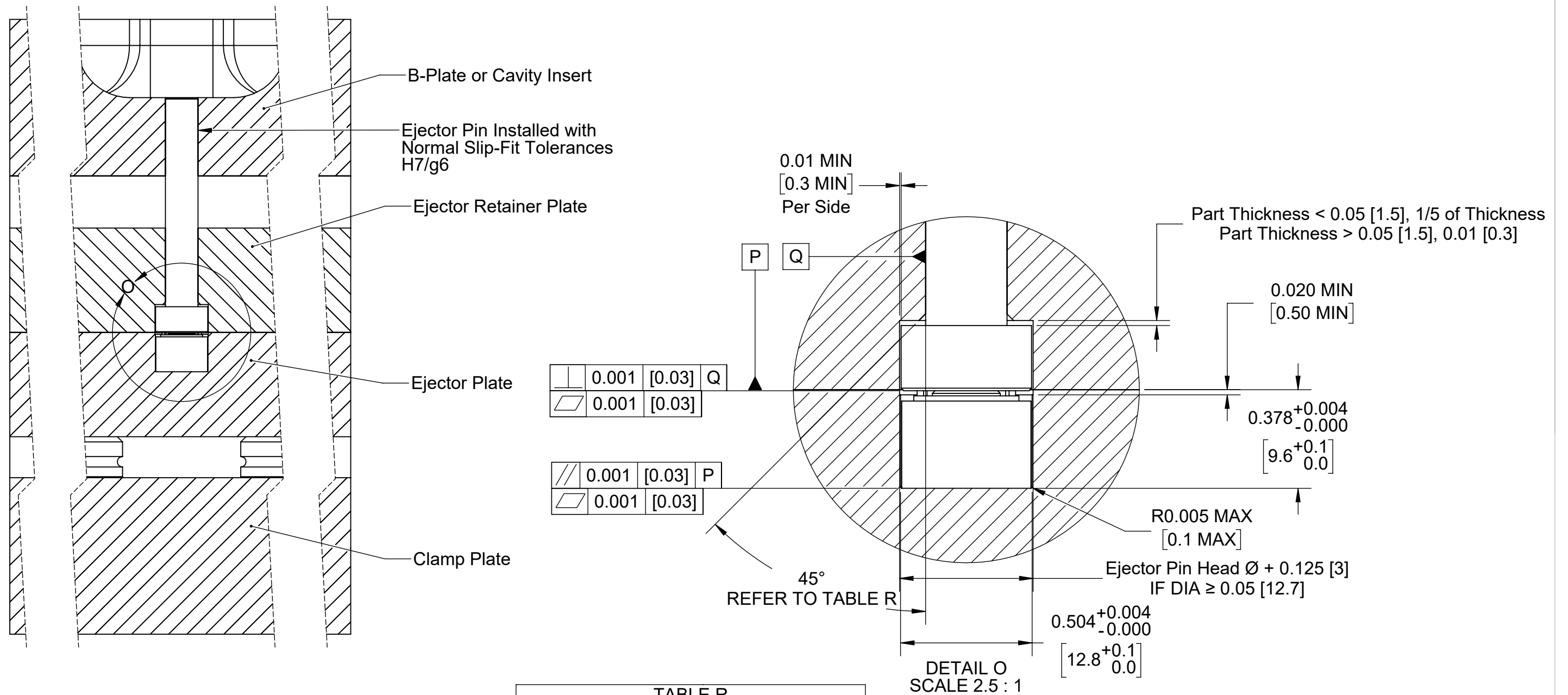

Ejector Pin Ø	Chamfer Length
0.04–0.08 [1.0–2.0]	0.01 [0.3]
0.10–0.20 [2.5–5.0]	0.02 [0.4]
0.24–0.40 [6.0–10.0]	0.025 [0.6]

- NOTES:
1. CLAMP PLATE APPLICATIONS REQUIRE GUIDED EJECTION
 2. EJECTOR AND TRANSFER PIN CONCENTRICITY MUST BE WITHIN 0.030" [0.76] OR 10% OF EJECTOR PIN DIA, WHICHEVER IS SMALLER.
 3. ENCLOSED EJECTOR BOX SUGGESTED.
 4. DO NOT SCALE PRINT
 5. BREAK ALL SHARP EDGES, 0.005 [0.03] R MAX
 6. DIMENSIONS IN INCHES [MM], UNLESS NOTED
 7. TOLERANCES UNLESS SPECIFIED:
 XXX = ±0.003 [0.08]
 XX = +0.01 [0.3]
 ANGLES = ±3° 30°

<p>3111 Park Street, Traverso City, NJ 08006 201-244-2111 www.rjg.com</p>	Description: 9204 Sensor Installation
	Drawn: K.J.Brettschneider
	Design:
	Check: M.Groleau
Date: 09.24.2021	

Single-Channel Piezoelectric 12.6 mm Sensor (9204) Installation—Ejector Plate Installation

NOTE: Lynx sensor electronics case mounted in the orientation as shown to prevent damage to components.

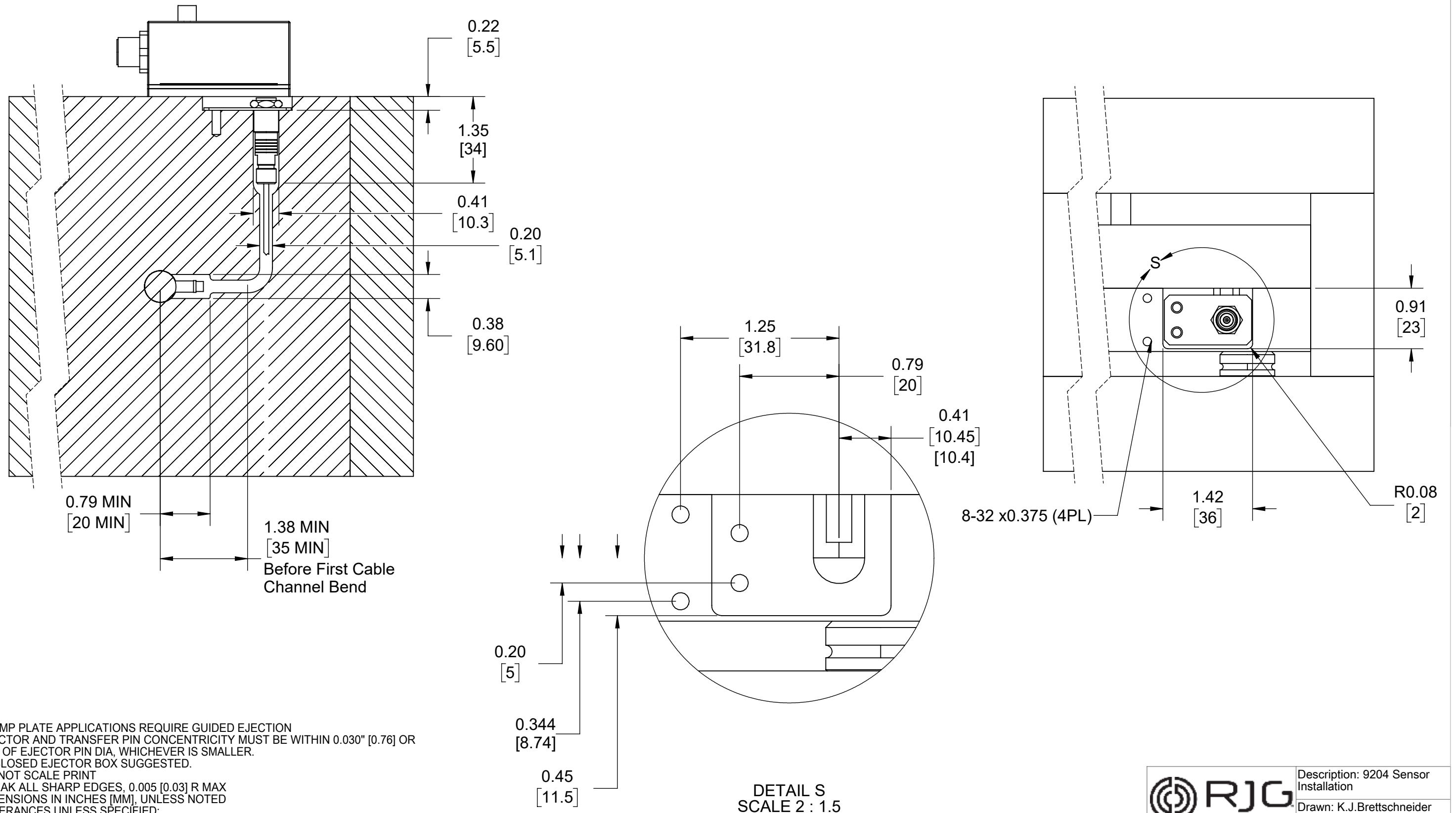

- NOTES:
1. CLAMP PLATE APPLICATIONS REQUIRE GUIDED EJECTION
 2. EJECTOR AND TRANSFER PIN CONCENTRICITY MUST BE WITHIN 0.030" [0.76] OR 10% OF EJECTOR PIN DIA, WHICHEVER IS SMALLER.
 3. ENCLOSED EJECTOR BOX SUGGESTED.
 4. DO NOT SCALE PRINT
 5. BREAK ALL SHARP EDGES, 0.005 [0.03] R MAX
 6. DIMENSIONS IN INCHES [MM], UNLESS NOTED
 7. TOLERANCES UNLESS SPECIFIED:
 XXX = ±0.003 [0.08]
 XX = +0.01 [0.3]
 ANGLES = ±3° 30°

DETAIL S
SCALE 2 : 1.5

 <p>3111 Park Street, Traverse City, MI 49686 231-944-2111 www.rjg.com</p>	Description: 9204 Sensor Installation
	Drawn: K.J.Brettschneider
	Design: M.Groleau
	Date: 09.24.2021

Drawing Title: 9204-10

Four-Channel Piezoelectric 12.6 mm Sensor (9204) Installation

NOTE: REFER TO PAGES 9204-03 FOR CLAMP PLATE INSTALLATION, 9204-05 FOR CLAMP PLATE (HEAD-TO-HEAD INSTALLATION), AND 9204-08 FOR EJECTOR PLATE INSTALLATION.

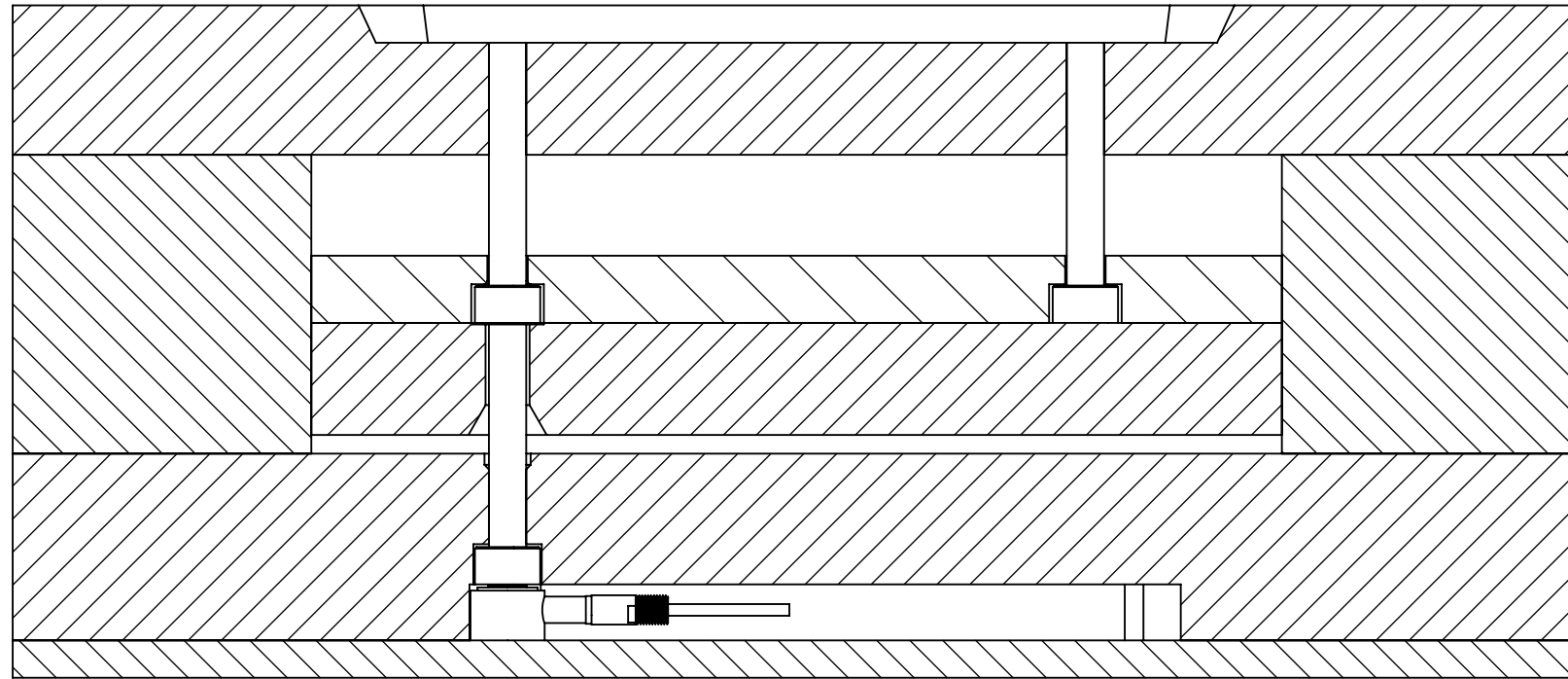

SECTION T-T
SCALE 4 : 5

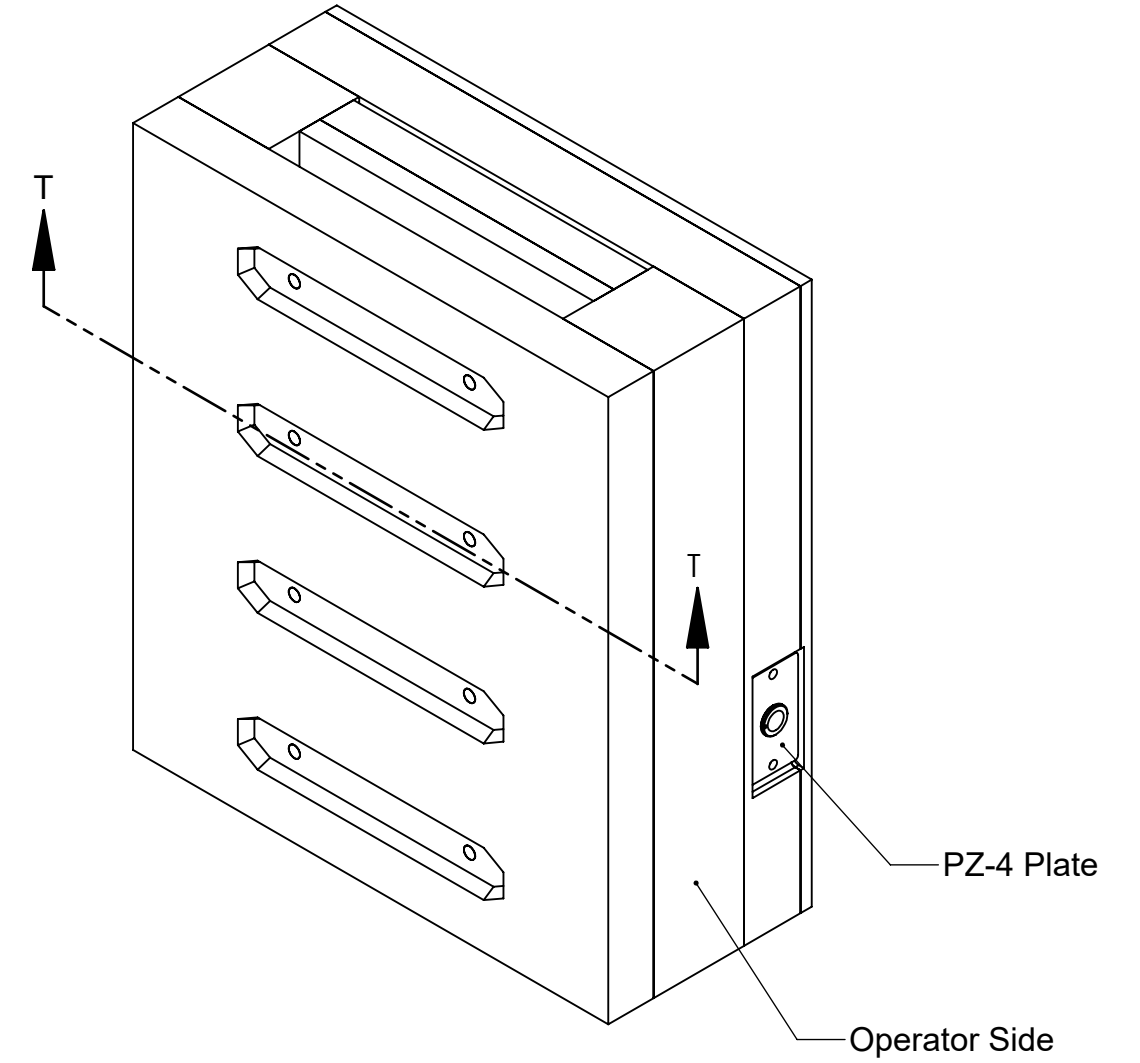

NOTES:

1. CLAMP PLATE APPLICATIONS REQUIRE GUIDED EJECTION
2. EJECTOR AND TRANSFER PIN CONCENTRICITY MUST BE WITHIN 0.030" [0.76] OR 10% OF EJECTOR PIN DIA, WHICHEVER IS SMALLER.
3. ENCLOSED EJECTOR BOX SUGGESTED.
4. DO NOT SCALE PRINT
5. BREAK ALL SHARP EDGES, 0.005 [0.03] R MAX
6. DIMENSIONS IN INCHES [MM], UNLESS NOTED
7. TOLERANCES UNLESS SPECIFIED:
XXX = ± 0.003 [0.08]
XX = ± 0.01 [0.3]
ANGLES = $\pm 3^\circ$ 30°



Description: 9204 Sensor
Installation
Drawn: K.J.Brettschneider
Design:
Check: M.Groleau
Date: 07.21.2020

Drawing Title: 9204-11

Four-Channel Piezoelectric 12.6 mm Sensor (9204) Installation

NOTE: REFER TO PAGES 9204-03 FOR CLAMP PLATE INSTALLATION, 9204-05 FOR CLAMP PLATE (HEAD-TO-HEAD INSTALLATION), AND 9204-08 FOR EJECTOR PLATE INSTALLATION.

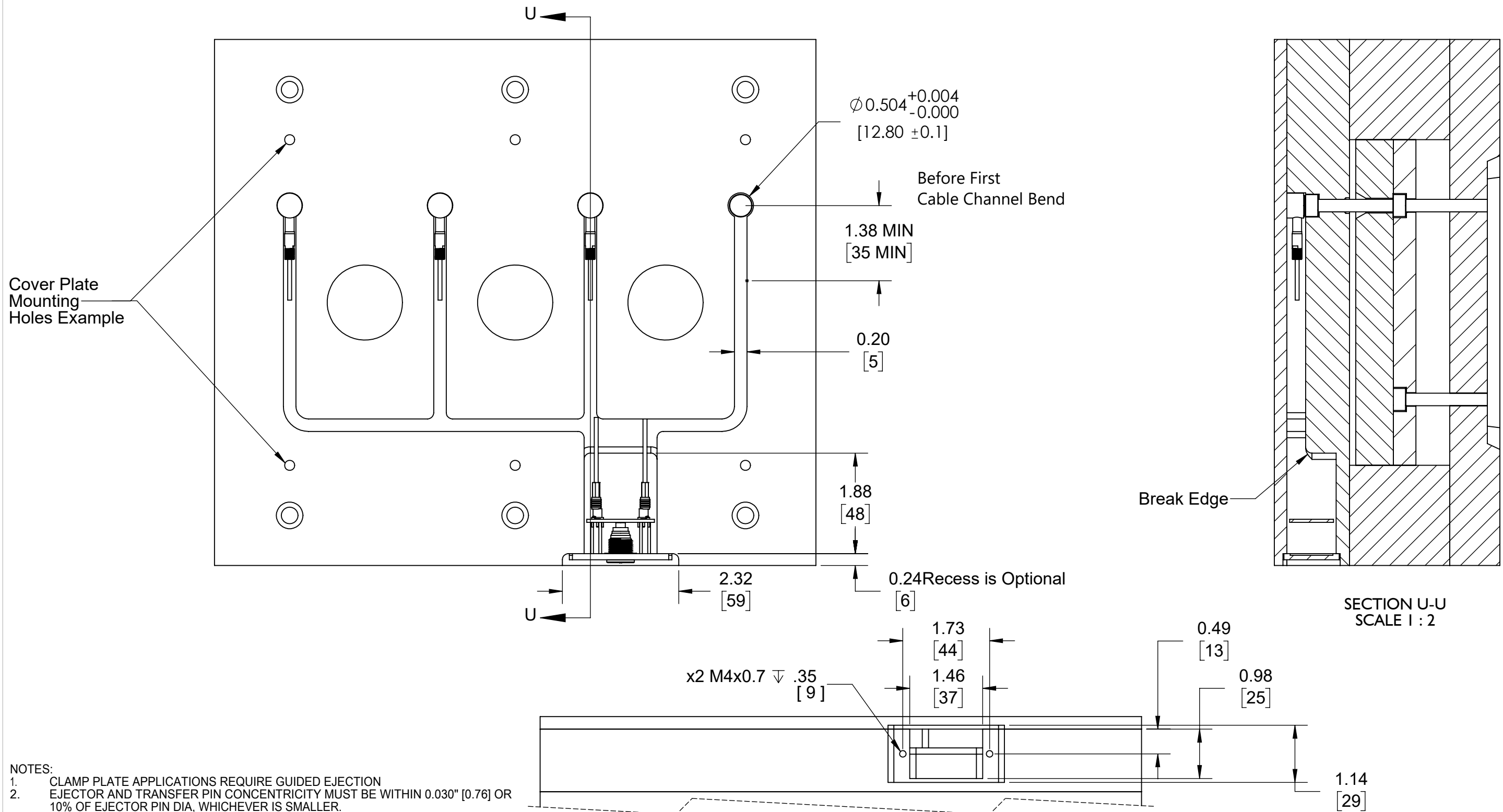

NOTES:

1. CLAMP PLATE APPLICATIONS REQUIRE GUIDED EJECTION
2. EJECTOR AND TRANSFER PIN CONCENTRICITY MUST BE WITHIN 0.030" [0.76] OR 10% OF EJECTOR PIN DIA, WHICHEVER IS SMALLER.
3. ENCLOSED EJECTOR BOX SUGGESTED.
4. DO NOT SCALE PRINT
5. BREAK ALL SHARP EDGES, 0.005 [0.03] R MAX
6. DIMENSIONS IN INCHES [MM], UNLESS NOTED
7. TOLERANCES UNLESS SPECIFIED:
 XXX = ±0.003 [0.08]
 XX = ±0.01 [0.3]
 ANGLES = ±3° 30°



Description: 9204 Sensor Installation
 Drawn: K.J.Brettschneider
 Design:
 Check: M.Groleau
 Date: 07.21.2020

Drawing Title: 9204-12

Eight-Channel Piezoelectric 12.6 mm Sensor (9204) Installation

NOTE: REFER TO PAGES 9204-03 FOR CLAMP PLATE INSTALLATION, 9204-05 FOR CLAMP PLATE (HEAD-TO-HEAD INSTALLATION), AND 9204-08 FOR EJECTOR PLATE INSTALLATION.

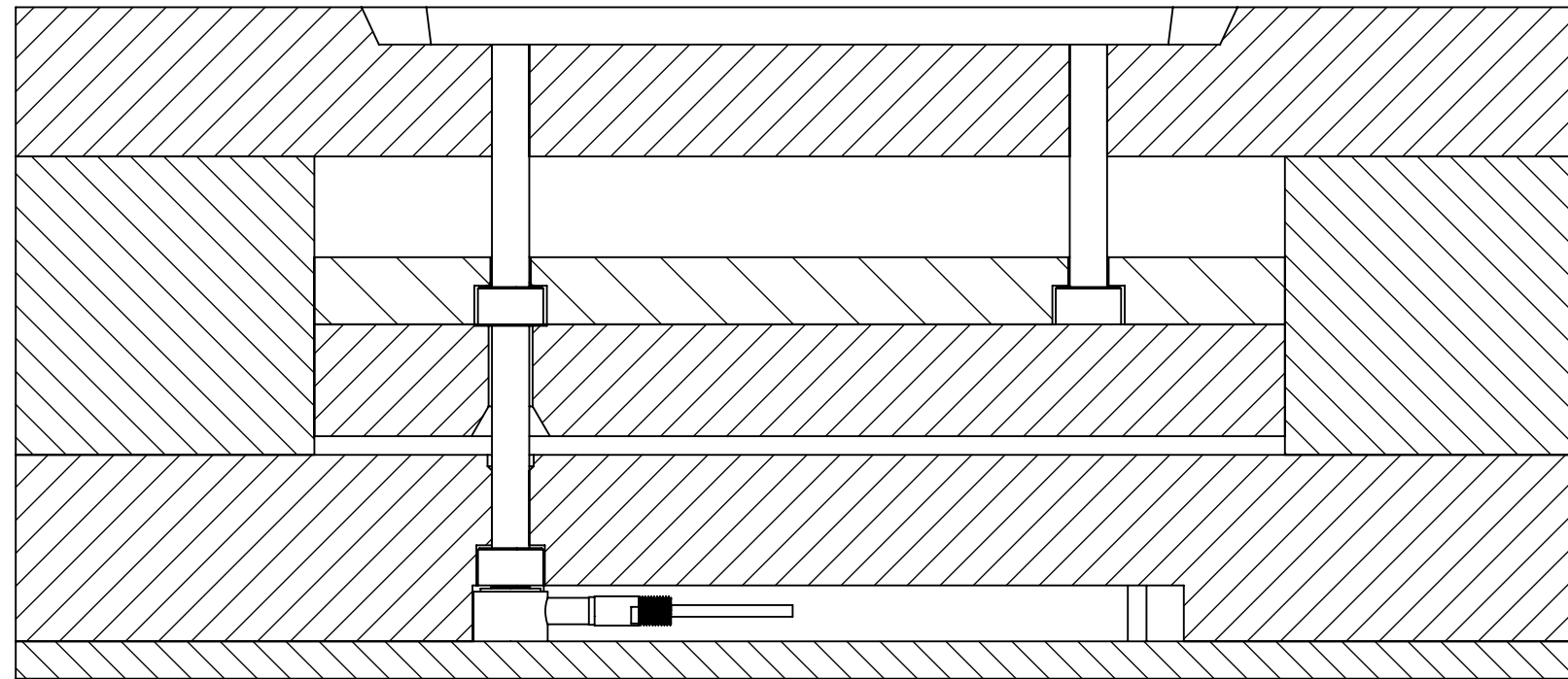

SECTION V-V
SCALE 4 : 5

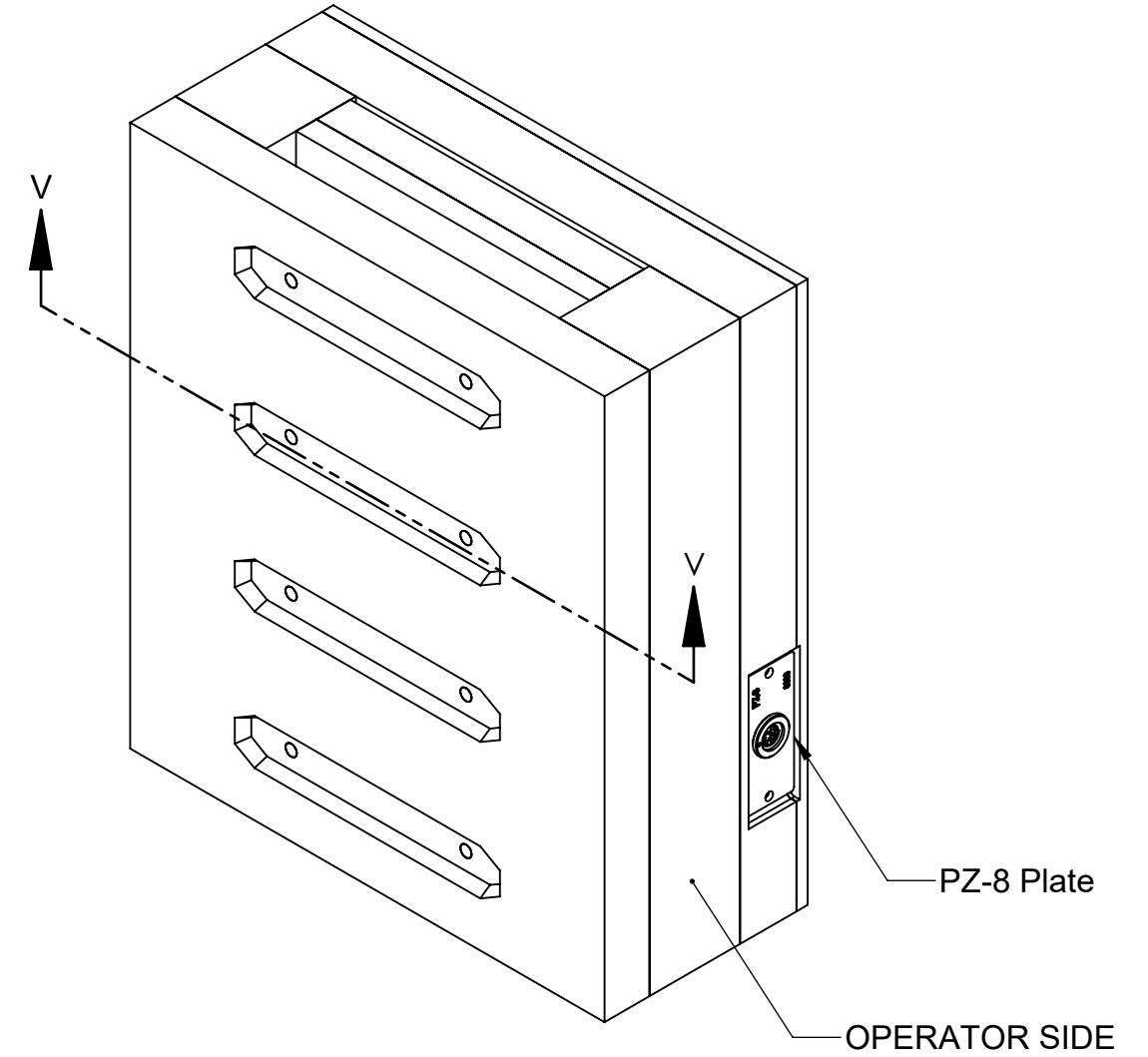

PZ-8 Plate

OPERATOR SIDE

NOTES:

1. CLAMP PLATE APPLICATIONS REQUIRE GUIDED EJECTION
2. EJECTOR AND TRANSFER PIN CONCENTRICITY MUST BE WITHIN 0.030" [0.76] OR 10% OF EJECTOR PIN DIA, WHICHEVER IS SMALLER.
3. ENCLOSED EJECTOR BOX SUGGESTED.
4. DO NOT SCALE PRINT
5. BREAK ALL SHARP EDGES, 0.005 [0.03] R MAX
6. DIMENSIONS IN INCHES [MM], UNLESS NOTED
7. TOLERANCES UNLESS SPECIFIED:
XXX = ± 0.003 [0.08]
XX = ± 0.01 [0.3]
ANGLES = $\pm 3^\circ$ 30°



Description: 9204 Sensor Installation
Drawn: K.J.Brettschneider
Design:
Check: M.Groleau
Date: 07.21.2020

Drawing Title: 9204-13

Eight-Channel Piezoelectric 12.6 mm Sensor (9204) Installation

NOTE: REFER TO PAGES 9204-03 FOR CLAMP PLATE INSTALLATION, 9204-05 FOR CLAMP PLATE (HEAD-TO-HEAD INSTALLATION), AND 9204-08 FOR EJECTOR PLATE INSTALLATION.

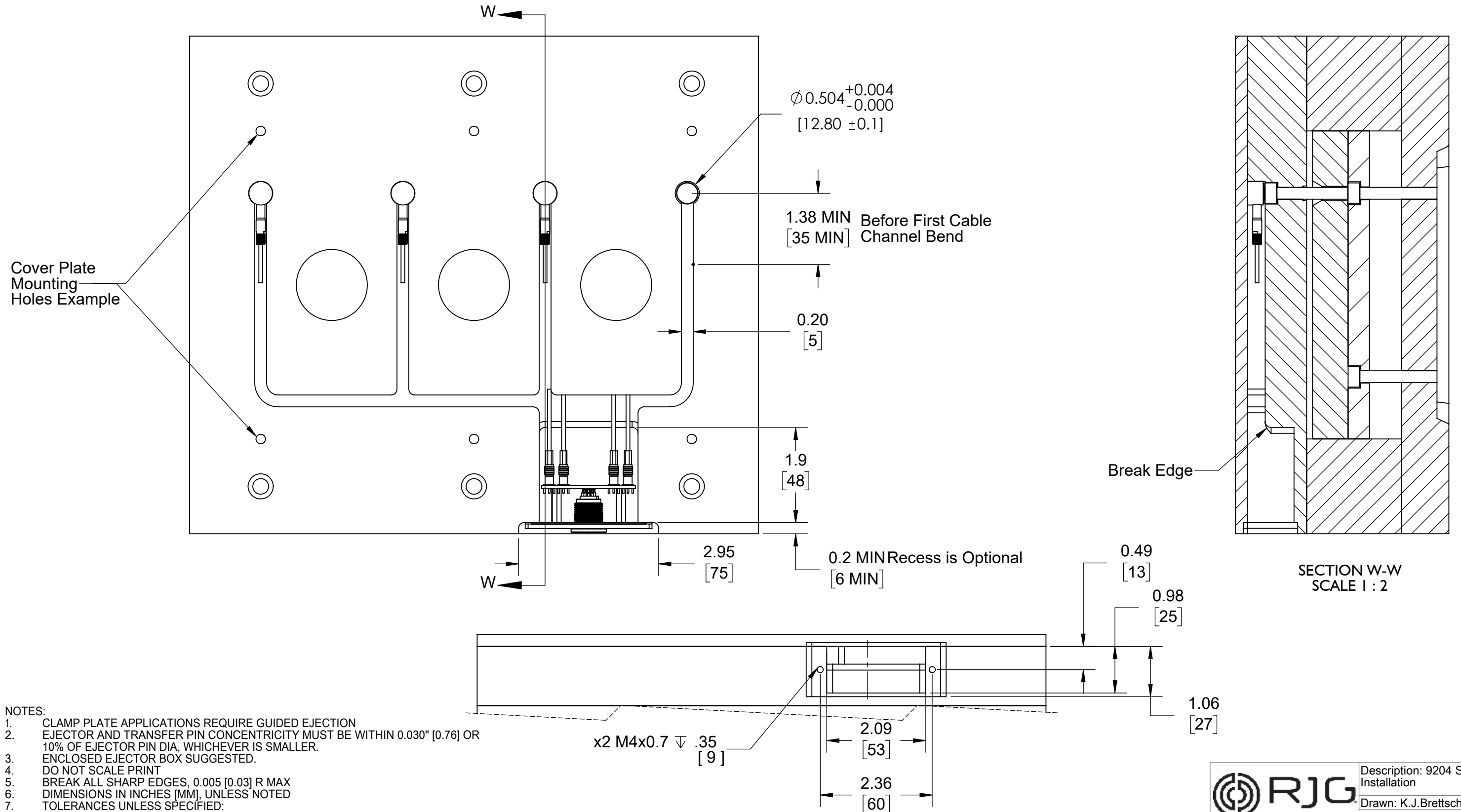

- NOTES:
1. CLAMP PLATE APPLICATIONS REQUIRE GUIDED EJECTION
 2. EJECTOR AND TRANSFER PIN CONCENTRICITY MUST BE WITHIN 0.030" [0.76] OR 10% OF EJECTOR PIN DIA, WHICHEVER IS SMALLER.
 3. ENCLOSED EJECTOR BOX SUGGESTED.
 4. DO NOT SCALE PRINT
 5. BREAK ALL SHARP EDGES, 0.005 [0.03] R MAX
 6. DIMENSIONS IN INCHES [MM], UNLESS NOTED
 7. TOLERANCES UNLESS SPECIFIED:
 XXX = ±0.003 [0.08]
 XX = ±0.01 [0.3]
 ANGLES = ±3° 30°

 <p>3111 Park Street, Traverse City, MI 49686 231-944-2111 www.rjg.com</p>	Description: 9204 Sensor Installation
	Drawn: K.J.Brettschneider
	Design:
	Check: M.Groleau
Date: 07.21.2020	

9204 Sensor Installation—Contoured Pin Angle Specification

NOTE: Contoured/angled pins (asymmetric) not to exceed 30° MAX unless pin design is symmetrical to provide even, downward pressure across pin surface to loading of sensor. Contact RJG Customer Support for assistance in verification of contoured/angled pin use.

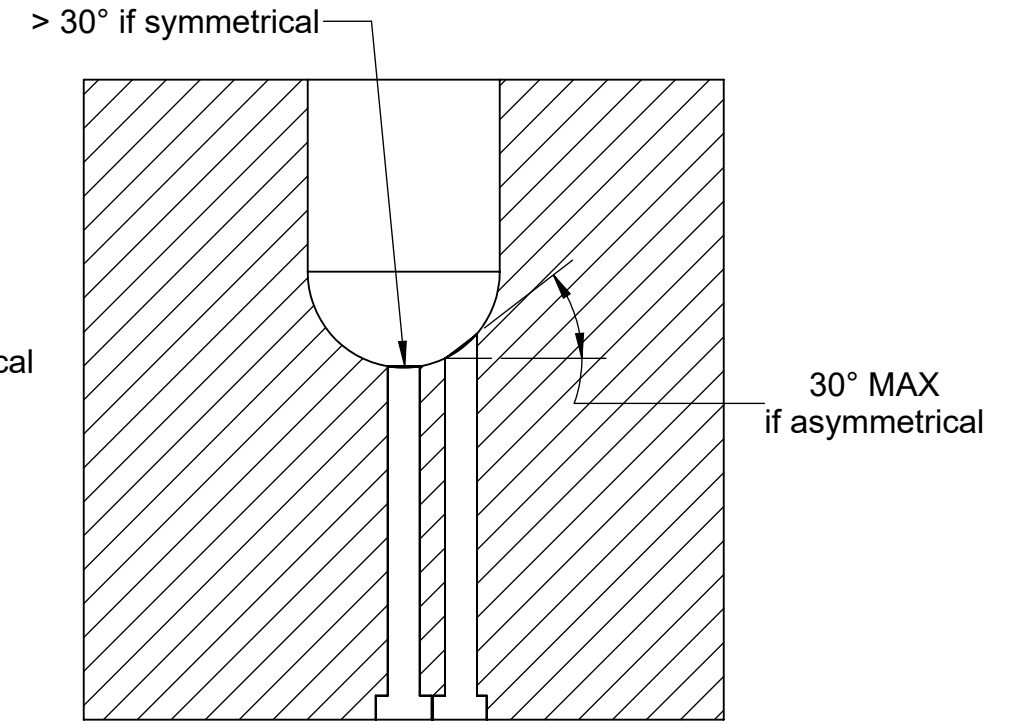
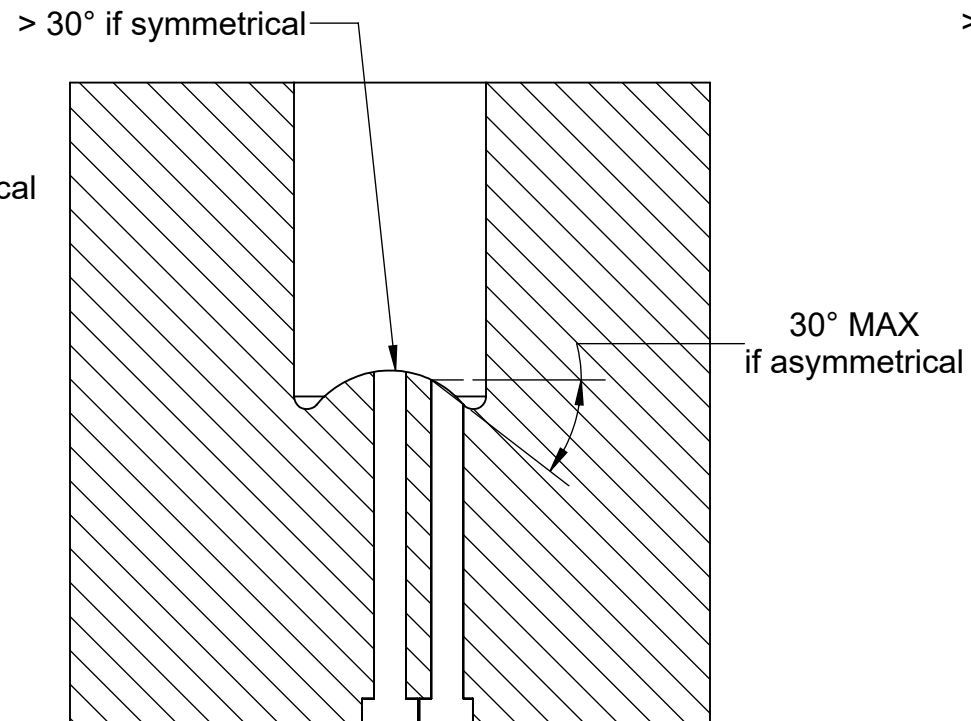
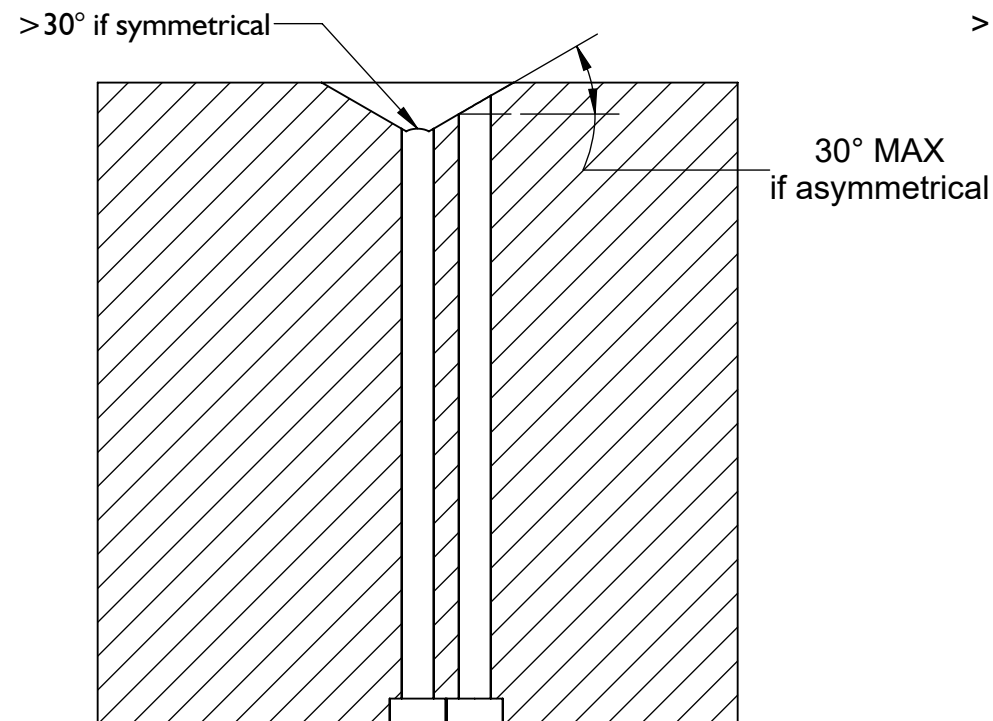
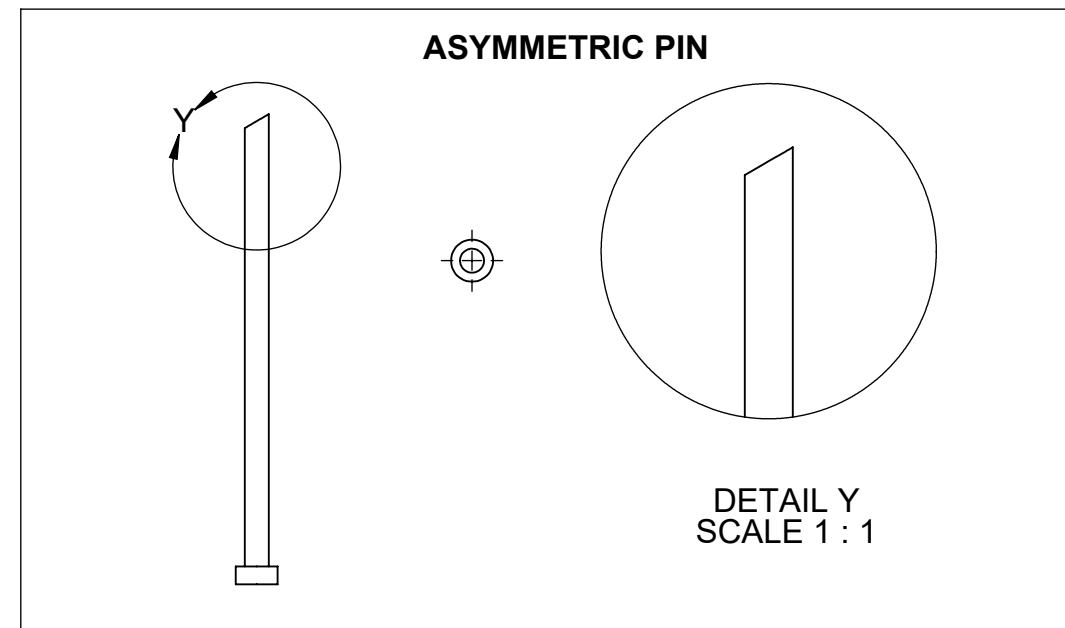
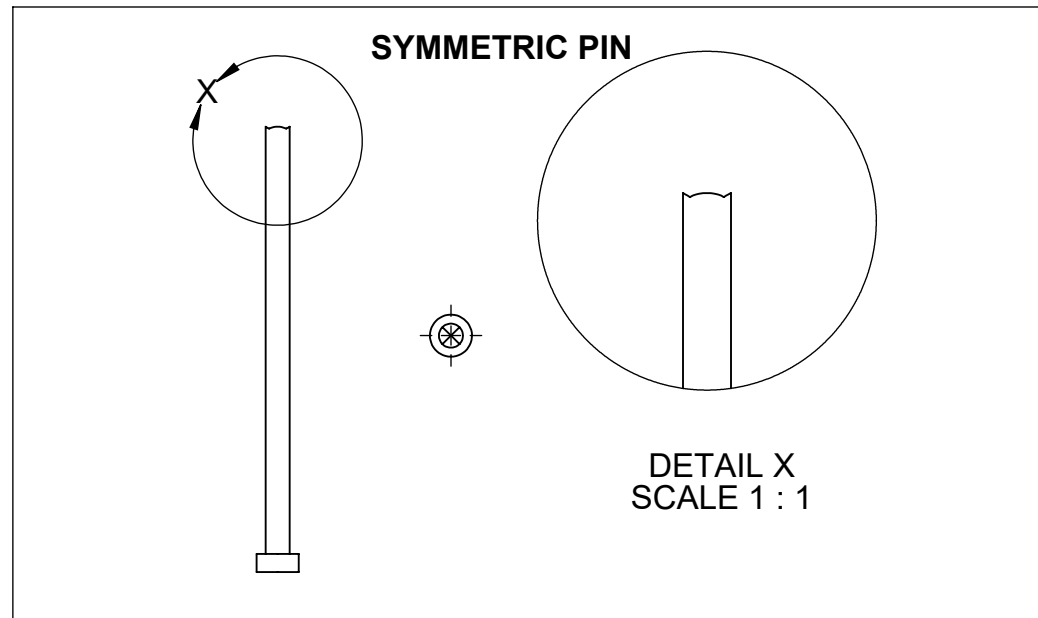

NOTES:

1. CLAMP PLATE APPLICATIONS REQUIRE GUIDED EJECTION
2. EJECTOR AND TRANSFER PIN CONCENTRICITY MUST BE WITHIN 0.030" [0.76] OR 10% OF EJECTOR PIN DIA, WHICHEVER IS SMALLER.
3. ENCLOSED EJECTOR BOX SUGGESTED.
4. DO NOT SCALE PRINT
5. BREAK ALL SHARP EDGES, 0.005 [0.03] R MAX
6. DIMENSIONS IN INCHES [MM], UNLESS NOTED
7. TOLERANCES UNLESS SPECIFIED:
 XXX = ±0.003 [0.08]
 XX = +0.01 [0.3]
 ANGLES = ±3° 30°

 <small>3111 Park Street, Traverse City, MI 49606 231-944-2111 WWW.RJG.MI</small>	Description: 9204 Sensor Installation
	Drawn: K.J.Brettschneider
	Design: M.Groleau
	Check: M.Groleau
	Date: 09.24.2021